



Formula Blast Cabinet Range



Operating & Maintenance Instructions

Guyson International Limited
Snaygill Industrial Estate
Keighley Road
Skipton
North Yorkshire
BD23 2QR

Tel: 01756 799911

E-mail: info@guyson.co.uk
Website: www.guyson.co.uk



Table of contents

1. Introduction	3
1.1 Safety recommendations	3
1.2 Electrical specification	3
2. Data sheet	4
2.1 General information	4
2.2 Air consumption tables	4
2.2.1 Air flow measured in m ³ /hr at different pressures measured in bar	4
2.2.2 Air flow measured in CFM at different pressures measured in psi	4
3. Installation	5
3.1 Location	5
3.2 Assembly	5
3.2.1 Compressed air connections	6
3.2.2 Electrical connections	7
4. Testing installation	8
4.1 Testing installation procedure	8
4.2 Media levels	9
4.2.1 Adding media to hopper	9
5. Machine settings	10
5.1 Blast settings	10
5.1.1 Blasting pressure	10
5.1.2 Media pick-up tube	11
5.1.3 Stand-off distance	12
5.1.4 Angle of blasting	12
5.2 Extraction settings	13
5.2.1 Dust collector	13
6. Operation	14
6.1 Operating procedure	14
7. Maintenance	15
7.1 Daily	16
7.1.1 Breather pad	17
7.1.2 Viewing window	18
7.1.3 Empty dust collector bin	18
7.1.4 Filter cleaning	19
7.1.4.1 Replacing the filter sleeves on an F21/F41 dust collector	20
7.1.5 Compressed air filter	20
7.1.6 Hoses	21
7.1.7 Blast nozzles	22
7.1.7.1 400 Blast gun	22
7.1.7.2 400 Trigger gun	22
7.1.7.3 Blast nozzle	22
7.1.7.4 Airjet	24
7.1.7.5 Media entry	24
7.1.8 Door seals	24
7.1.9 Topping up media	24
7.2 Weekly	25
7.2.1 Gauntlets	25
7.3 Monthly	26
7.3.1 Emptying media	26
8. FAQ's	27
9. Spares and servicing	28
9.1 Recommended spares list	29
10. Appendices	31



1. Introduction

This manual should be regarded as part of the product and must be retained for the life of the machine. The manual must be passed to any subsequent owners of the machine.

Any amendments should be attached to the original manual. Machine identification and serial number can be found on the identification plate fixed to the machine body.

1.1 Safety recommendations

Users of Guyson equipment are advised to make sure they have identified any hazards associated with their specific air washing processes, including:

- Use of compressed air
- Fire/explosion risks
- Suitable procedures for dealing with fire hazards
- Production of carcinogenic or toxic substances from component surface removal
- Any other known hazards

Users are responsible for ensuring that they have implemented any current regulatory requirements, e.g. COSHH, to deal with any potential risks and/or hazards associated with their processes.

ATEX ZONE DESIGNATION

The ATEX Directives 2014/34/EU (product requirements) and 99/92/EC (user requirements) are implemented by the Equipment and Protective Systems intended for use in potentially explosive Atmospheres Regulations 1996 (EPS) and the Dangerous Substances and Explosive Atmosphere Regulations 2002 (DSEAR) respectively.

We are able to provide equipment that is suitable for use in a hazardous area, and/or equipment that is suitable for use when a hazardous area is created within a system, but it is the end users' responsibility to classify the area in which the equipment is to be used and/or the explosivity of any internal atmosphere created within the system. This is defined in Section 2, Article 3 to 9 of the 99/92/EC Directive (ATEX 137).

Unless we have been advised otherwise, we have to assume that the equipment will be used in an area that is not classified as potentially explosive, and uses a process which will not create an explosive atmosphere within the equipment.

1.2 Electrical specification

Electrical wiring on Guyson equipment conforms to:

- BSEN 60204-1:2006
- IEC 60204-1:2005



2. Data sheet

2.1 General information

Cabinet	Formula 1200	Formula 1400	Formula 1600
Cabinet height (mm)	785	1526	1694
Cabinet width (mm)	600	815	1070
Cabinet depth (mm)	505	605	760
Armhole height (mm)	N/A	1104	1104
Cabinet outlet diameter (mm)	100	100	100

Dust collector	F21	F41
Dust collector height (mm)	1041	1041
Dust collector width (mm)	450	450
Dust collector depth (mm)	328	553
Dust collector inlet (mm)	100	100
Extraction outlet	Open exhaust	Open exhaust
Measured air flow (with open inlet/outlet) (m ³ /min)	7	7
Number of filters	2	4
Type of filter	Fabric filter - Polyester needlefelt - Scrim reinforced	Fabric filter - Polyester needlefelt - Scrim reinforced
Main filter area	0.9 m ² 8.75 ft ²	1.8 m ² 17.44 ft ²
Filter cleaning system	Manual	Manual

2.2 Air consumption tables

2.2.1 Air flow measured in m³/hr at different pressures measured in bar

Air-jet Bore (mm)	Guyson gun type	Blast pressure (bar)				
		2	3	4	5	6
2.0	400	4.8	7.2	9.0	11.4	13.8
2.4	400	6.6	10.2	13.8	17.1	20.4
2.8	400	10.2	15.0	19.2	25.2	29.4
3.3	400	15.6	22.8	28.2	35.4	40.8

2.2.2 Air flow measured in CFM at different pressures measured in psi

Air-jet Bore (mm)	Guyson gun type	Blast pressure (psi)					
		30	40	50	60	70	80
2.0	400	3	4	4.5	5.5	6.5	7.5
2.4	400	4	5	7	8	9	11
2.8	400	6	8	10	12	14	16
3.3	400	10	12	15	17	20	22

3. Installation

The system comprises of the following unit:

- Formula Cabinet
- Dust Collector

Remove packing materials and check inside cabinet for loose items.

3.1 Location

The equipment must be located on a clean, dry surface.

The Formula 1400 and 1600 Cabinets are designed to stand on the floor, the Formula 1200 Cabinet is designed to stand on a workbench approximately 700 mm high. Locate the cabinet in the required position and orientation; always allow sufficient room around the units to fully open doors/lids and to give access for operation and maintenance.

Care should be taken to ensure all parts of the system are level

3.2 Assembly

Connect the cabinet outlet on the blast cabinet to the dust collector inlet:

Connect the flexible extraction hose from the cabinet outlet to the dust collector inlet using the sealing bands and hose clamps supplied.

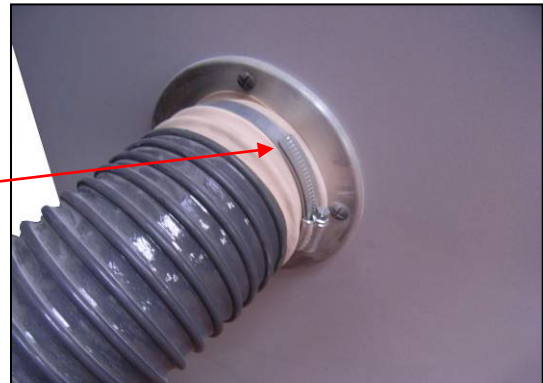

3.2.1 Compressed air connections

The air supply should be from a manual shut-off dial that will exhaust down-stream air and be clean and dry.

The machine requires a compressed air supply at a maximum of 6.0 bar (90 psi) at the filter inlet. This should be supplied through pipework with a minimum bore of 10mm with no restrictive air fittings. The filter inlet has a 3/8" BSP fitting, as shown below.

Connect the main compressed air supply to the pneumatic isolator valve

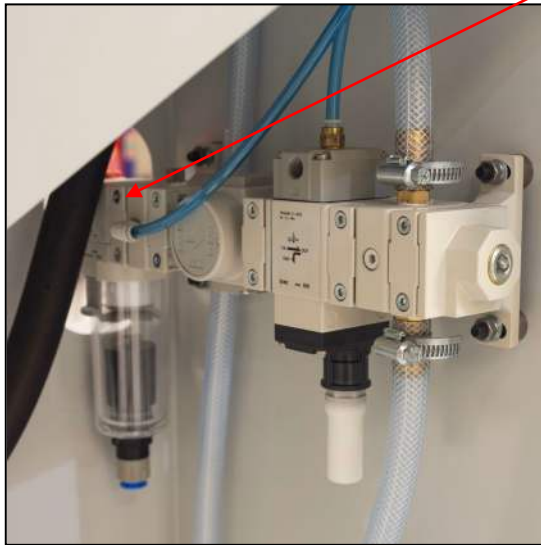

Take care that any jointing material (e.g. PTFE tape) does not enter the pipework.

3.2.2 Electrical connections

Electrical installations should only be carried out by qualified electricians

Please see “Electrical Installation of Dust Collectors and Cyclones” in the appendix

A power supply should be taken to the starter box situated on the side of the dust collector.



The electrical supply to the lighting on F1200, F1400 and F1600 cabinets is via an IEC lead.



4. Testing installation

4.1 Testing installation procedure

After completing all the connections the cabinet operation should be checked.

Do not open the air supply at this stage.

- Switch on main electrical power supply
- Switch on cabinet light
- Start the dust collector:
 - The direction of the impellor motor should be checked visually against the arrow on the motor. If rotation is in the wrong direction on the single phase motor, then Guyson International should be contacted for more information.

NOTE: Air will flow from the outlet even if the fan rotation is wrong, but only at a low level, so rotation must be checked visually.



On a F41 dust collector the motor is inside. Unclip the catches and remove the front panel to check its rotation.

The best way to do this task is by starting then stopping the dust collector and watch the fan as it slows down.

- Turn on the air supply by opening the main air valve
- Set pressure regulator to required air wash pressure
- Check all in-line connections for leaks and possible blockages
- Insert both arms through the armhole entries
- Depress the foot pedal (or trigger valve for Formula 1200)
- Check for a steady air blast from the gun and for possible leaks
- Remove arms from gauntlets, isolate cabinet from compressed air supply and ensure all compressed air is discharged from the system, open cabinet and add blast media.

4.2 Media levels

The media should be added to the cabinet hopper; $\frac{1}{4}$ of a 25kg bag of media should suffice.

4.2.1 Adding media to hopper

- Turn off the dust collector
- Open the cabinet door
- Pour media into the hopper
- Close the door
- Turn the dust collector on

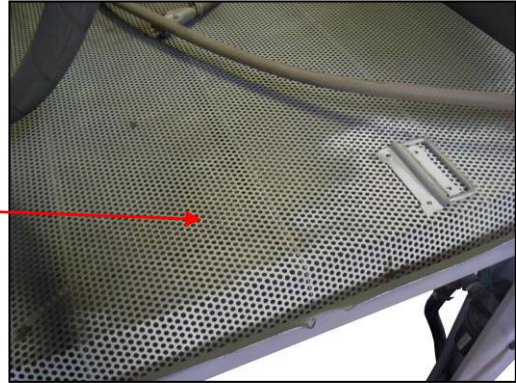

5. Machine settings

5.1 Blast settings

The blast settings should be set in the order they appear in the following sections.

5.1.1 Blasting pressure

Air pressure controls the speed at which the blast media leaves the nozzle. Blasting speed increases at higher pressures and shortens operation time. Never use a higher blast pressure than necessary to achieve the finish required, this will normally be less than 80p.s.i (6 bar).

- Higher pressure air is less economical
- It may distort or damage components
- Greater media breakdown means higher media consumption
- Noise increases

Adjust the blast gun pressure using the control knob on the right-hand side of the cabinet. The gauge shows the set pressure. Ensure the knob is pushed in to lock the pressure.

The protective cover can also be removed on the pneumatic regulator, by pressing the two clear tabs together. This will then allow you to move the two green needles, to set a working pressure range e.g., between 50 & 80 PSI. This range can be set accordingly to the pressure range best suited for your parts. If you are unsure on this you can always set it to 0 and 80 PSI, to show the maximum working ranges of the machine.



5.1.2 Media pick-up tube

The setting of the pick-up tube in the media box has a significant effect on the blasting performance. Adjustment varies with the media density, with denser media requiring more air to circulate them.

The greater the flow of media from the mixer box to the blast gun, the higher the rate of wear on media hose, blast nozzle.

- Check that there is a supply of free-flowing, dry media to the mixer box
- With compressed air flowing through the blast gun gradually move the pick-up tube into the mixer box with the chamfer facing upwards while a colleague watches the media flow from the nozzle.

The pick-up tube is in the right position when you are just able to see the media stream leaving the nozzle. If the media stream is intermittent then the pick-up tube has been pushed too far in.

- Moving the pick-up tube out decreases media flow
- Moving the pick-up tube in increases media flow
- Lock the pick-up tube in place with the retaining screw
- Further adjustment should not be needed whilst using the same media

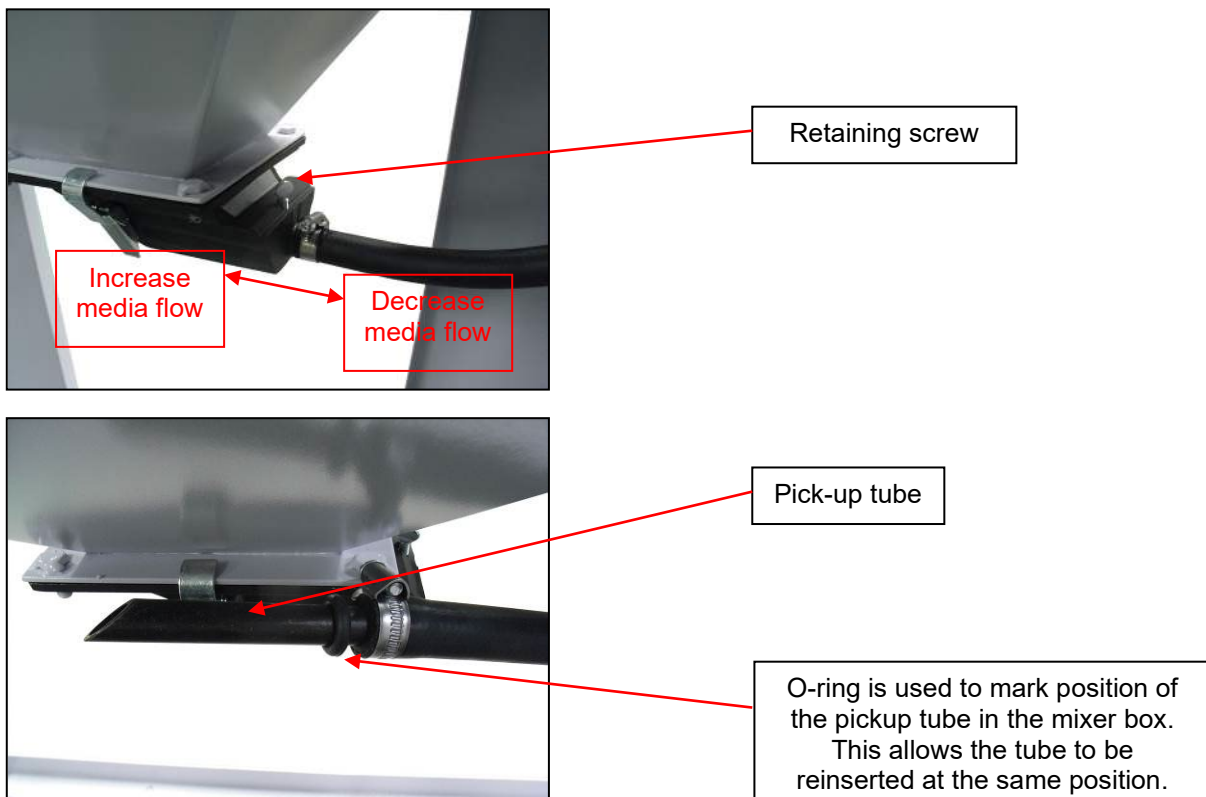



5.1.3 Stand-off distance

This is the distance of the gun nozzle from the component. The stand-off distance should not normally be reduced below 50 mm as media from the nozzle will be deflected or slowed down by media ricocheting from the surface being blasted.

The impact of the media can be affected by the stand-off distance and the air pressure. The type of media will influence this but a larger blast area may be achieved by increasing both the stand-off distance and the blast air pressure.

5.1.4 Angle of blasting

The optimum angle for blasting for surface finishing is between 90 and 60 degrees to the horizontal. Shallower angles can cause surface damage or compromise material properties. Greater angles than this can be used for deposit removal where the surface finish is not critical and with softer media.

Blast guns should be angled to minimise interference between the outputs from different guns. This will avoid disrupting the speed and direction of media between nozzle and component.

Always position guns pointing away from any cabinet openings; this minimises the risk of media being blasted out of the cabinet.

5.2 Extraction settings

5.2.1 Dust collector

The air-flow must be sufficient to create a slight negative pressure inside the cabinet to prevent dust from blowing out. The airspeed must also be high enough to carry the dust out of the cabinet and up the extraction hose to the inlet of the dust collector. This varies with the size and weight of blast media.

The suction in the dust collector should be such that a minimum amount of media is transferred into the dust collection system.

This is altered with the damper on the dust collector outlet:

- Opening the damper increases the suction
- Closing the damper reduces the suction

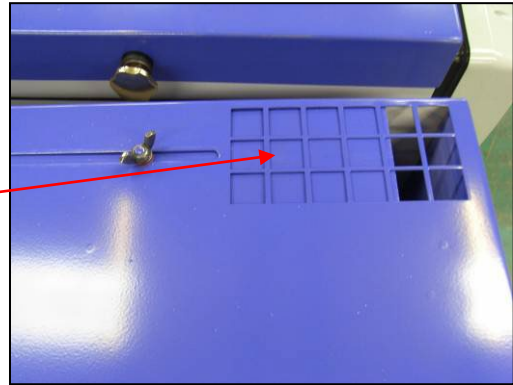

When setting the dampers/blast gates always keep the extraction air-flow to the minimum needed to avoid pressurisation of the cabinet during blasting. Over time the filters in the dust collector will become clogged with dust, and an increased air-flow may be necessary between filter changes and maintenance. In systems with a cyclone the extraction should be set so that a minimum amount of media is transferred into the dust collection system.

Always check the waste bin for good media when adjusting any settings.

Never try to extract reusable media for reuse in the machine.

6. Operation

6.1 Operating procedure

- Perform daily maintenance tasks (see section [7.1](#))
- Switch on main electrical power supply
- Switch on cabinet light
- Start the dust collector
- Turn on the air supply by opening the main air valve
- Ensure any component is grease-free and dry before blasting
- Open the cabinet door
- Place component in cabinet
- Position the blast gun so that they will be easily reached when using the gauntlets/gloves and sleeves
- Close the cabinet door securely
- Insert both arms through the armhole entries
- Depress the foot pedal/trigger valve. Doors will lock and media will exit from the gun nozzle
- Move the nozzle jet across the component surface at a suitable distance, refer to blast gun settings (see section [5.1.3](#))
- The component should be blasted evenly
- When the blasting is complete, release the foot pedal/trigger valve. Door interlocks will time out.
- The door can now be opened, and the component can be removed for inspection
- Further blasting may be necessary, or an adjustment to one or more of the machine or blast settings (see section [5.1](#))

7. Maintenance

The frequency of any maintenance schedule and the replacement of parts are determined by the amount of use and operating conditions. Maintenance intervals will be determined by experience of machine-use over time. The following periods are recommended for initial trial periods until a pattern is established.



ENSURE ALL AIR SUPPLIES ARE TURNED OFF AND THE SYSTEM IS FULLY EXHAUSTED BEFORE PERFORMING ANY MAINTENANCE



THE DUST COLLECTOR SHOULD BE FULLY ISOLATED BEFORE PERFORMING ANY MAINTENANCE. A LOCK-OUT AND TAG PROCEDURE SHOULD BE IN PLACE TO PREVENT THE MACHINE FROM BEING STARTED PRIOR TO THE COMPLETION OF MAINTENANCE.



PPE: GUYSON RECOMMENDS THAT AS A MINIMUM, OPERATIVES SHOULD USE A DUST MASK AND SAFETY GLASSES WHEN PERFORMING MAINTENANCE OF ANY SORT. REFERENCE SHOULD BE MADE TO THE MATERIAL SAFETY DATA SHEET OF THE MEDIA BEING USED FOR ANY SPECIFIC PPE REQUIRED.



7.1 Daily

- Inspect breather pad (see section [7.1.1](#))
- Inspect the viewing window and anti-frost sheet (see section [7.1.2](#))
- Empty dust collector bin (see section [7.1.3](#))
- Clean the filters every four working hours (see section [7.1.4](#))
- Check compressed air filter (see section [7.1.5](#))
- Check hoses for signs of wear or damage (see section [7.1.6](#))
- Check blast nozzles for wear (see section [7.1.7](#))
- Check door seals and replace if necessary (see section [7.1.8](#))
- Check media levels regularly and top up if necessary (see section [7.1.9](#))

7.1.1 Breather pad

The breather pad should be checked to see if it is blocked. If it is, it can cause an excessive negative pressure in the cabinet. See below for how to change them if necessary.

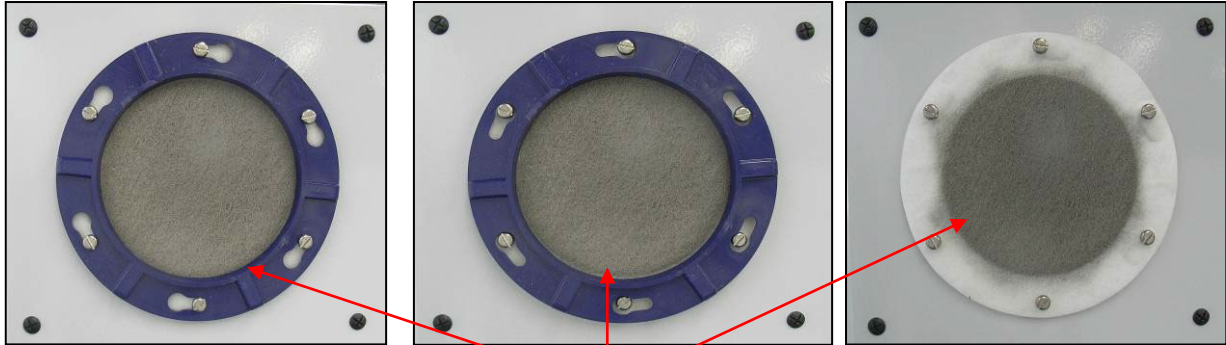

Slide breather bezel anti-clockwise and remove.

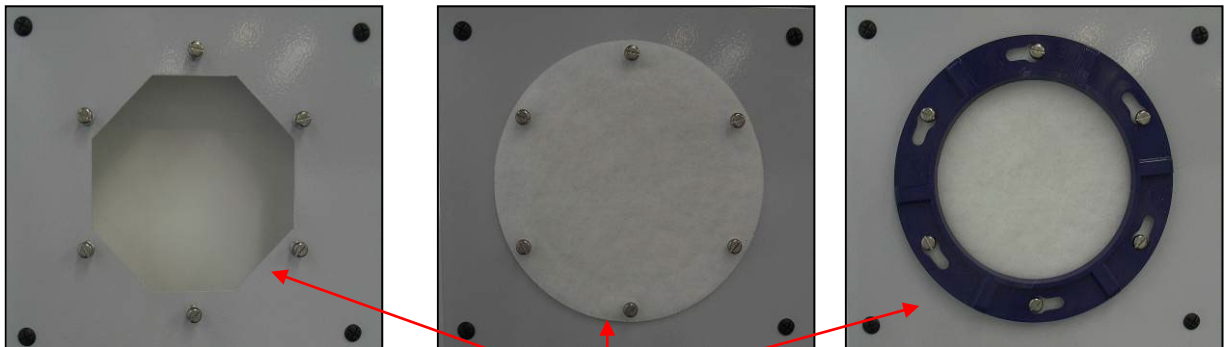

Remove and replace the breather pad (**Y1AB0001**). Return the breather bezel to the locked position.

7.1.2 Viewing window



Check that the view of the component to be air washed is not impaired by a dirty anti frost sheet (**P2PF0008 or P2PF0005 for the Formula 1200**) or glass (**P2GL0008 or P2GL0001 for the Formula 1200**). Replace if necessary.

7.1.3 Empty dust collector bin

The dust collector bin should be emptied twice daily. The bin is held in by clips on both sides of the dust collector. Release these to remove the bin from the dust collector.

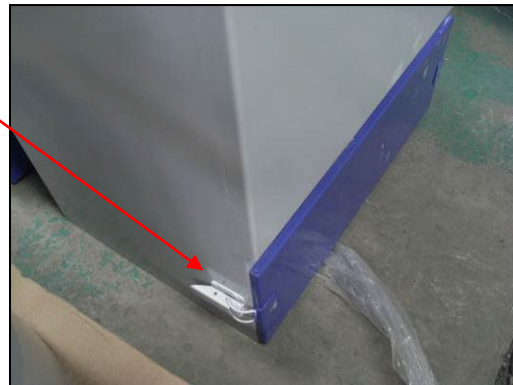

CARE SHOULD BE TAKEN WHEN HANDLING THE WASTE BIN AS IT MAY BE HEAVY

7.1.4 Filter cleaning



THE MOTOR SHOULD BE SWITCHED OFF WHEN USING THE CLEANING MECHANISM ON THE F21 DUST COLLECTOR

Filter cleaning must be carried out on a regular basis. Initially this should be carried out every four hours, until a working pattern is reached. On an F21/F41 dust collector the filter cleaning system is manual. Pull and push the knob back and forth to shake the filter clean.

After approximately five hundred hours use the dust will have worked its way into the body of the filter and cleaning with the cleaning mechanism will no longer clean sufficiently to allow enough air through. This will be evident by poor visibility in the cabinet and/or failure to extract the dust even with the dust collector damper fully open. A filter change will be necessary at this point.

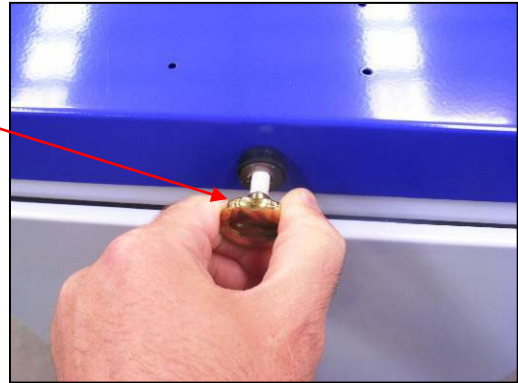

7.1.4.1 Replacing the filter sleeves on an F21/F41 dust collector



ENSURE THE FILTER IS CORRECTLY POSITIONED SO THAT DUST CANNOT BYPASS IT TO THE EXHAUST

ALSO ENSURE THAT THE MOTOR IS NOT RUNNING

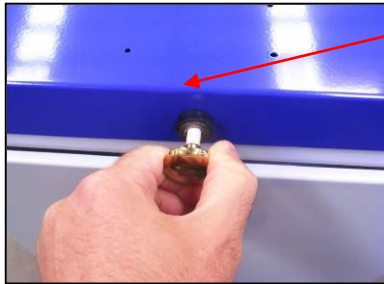

Shake filters and allow dust to settle

Remove front panel by unhooking latches

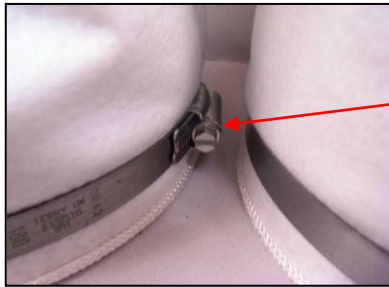

Remove large worm-drive clip from base of each filter sleeve

Unhook top of each filter from retainer clip



Carefully remove filter from dust collector.

Replace with new filter sleeve (Y1CA0000) by hooking top of filter onto retainer clip first then pass worm drive clip over the base of the sleeve and secure to base of dust collector. Re-fit front cover.



7.1.5 Compressed air filter

If the dust and light debris is dry and not clumping together then the compressed air filter is working correctly. If the dust and light debris is clumping together then there is a problem with the compressed air filter or your air supply. Guyson International should be contacted for more information.

7.1.6 Hoses

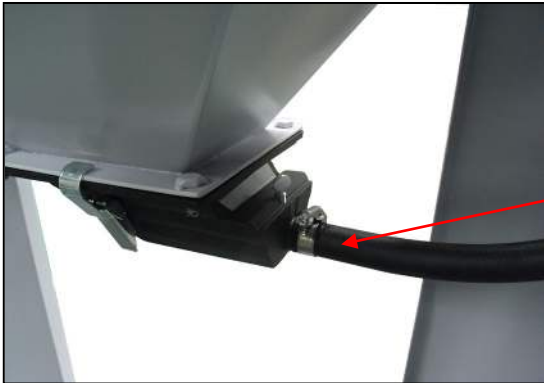

Check the media supply hoses (**R6TB0018 for F1400 and F1600, R6TB0014 for F1200**) for signs of wear and damage. Internal wear can be determined by feeling the rigidity of the tubing along its length. Any internal wear will result in the hose feeling soft where the hose wall is thinner. The first section to go is usually next to the pickup tube.

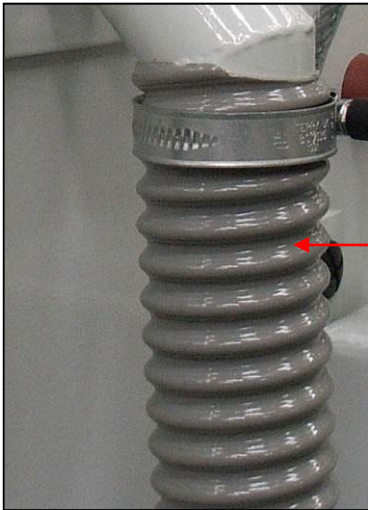

Check the extraction hoses for holes or breaks as these will affect the rate of extraction from the cabinet.

Item Code	Description
R6TB0030	Flexible exhaust ducting - standard - 100 mm bore (m)
R6TB0032	Flexible exhaust ducting - polyurethane - 100 mm (m)
P2HS0000	Hose sleeve - 100mm
P1HC0004	Hose Clip – 100mm

7.1.7 Blast nozzles

7.1.7.1 400 Blast gun

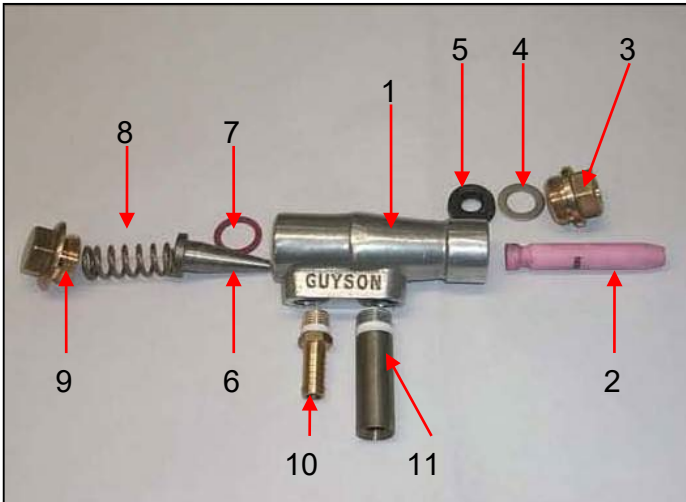

Pos	Item Code	Description
1		400 Gun body
2	D2BA0001	6.4mm Ceramic nozzle
2	D2BA0004	6.4mm Tungsten nozzle
3	D2AA0007	Nozzle locknut
4	P1WS0038	Nozzle washer
5	P2GT0012	Nozzle grommet
6	D1AA0000	2.0mm Airjet
6	D1AA0001	2.4mm Airjet
6	D1AA0002	2.8mm Airjet
7	P1WS0037	Airjet gasket
8	P2SG0000	Airjet coil spring
9	D2AA0008	Top nut
10	P4CG0001	1/4" Hosetail x 10mm
11	P4CG0002	Media entry 3/8" x 16mm

7.1.7.2 400 Trigger gun

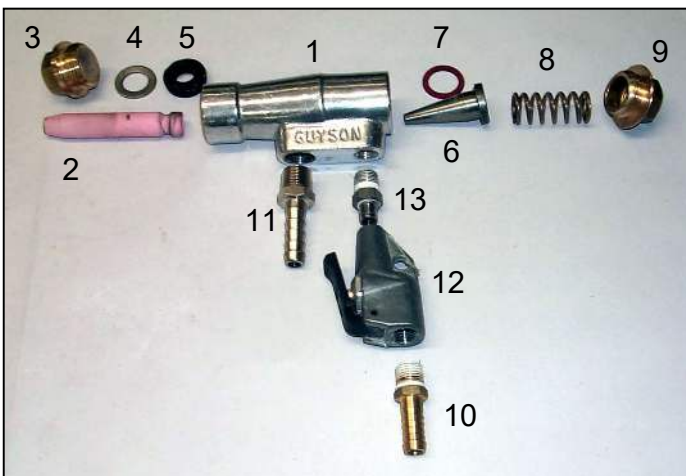

Pos	Item Code	Description
1		400 Gun body
2	D2BA0001	6.4mm Ceramic nozzle
2	D2BA0004	6.4mm Tungsten nozzle
3	D2AA0007	Nozzle locknut
4	P1WS0038	Nozzle washer
5	P2GT0012	Nozzle grommet
6	D1AA0000	2.0mm Airjet
6	D1AA0001	2.4mm Airjet
6	D1AA0002	2.8mm Airjet
7	P1WS0037	Airjet fibre washer
8	P2SG0000	Airjet coil spring
9	D1AA0008	Top nut
10	P4CG0001	Hosetail
11	P4CG0006	Media Entry
12	P4VL0425	Trigger valve
13	P4MN0070	Reducing nipple

7.1.7.3 Blast nozzle

Inspect the blast nozzle for wear. When the bore size has increased by 20% (6mm bore @ 20% = 7.2mm) then the nozzle needs to be replaced. The effective bore of a nozzle can be quickly checked by use of a twist drill bit.

The nozzle should be withdrawn from the gun body after 8 hours blasting and rotated by 5° to avoid uneven wear.

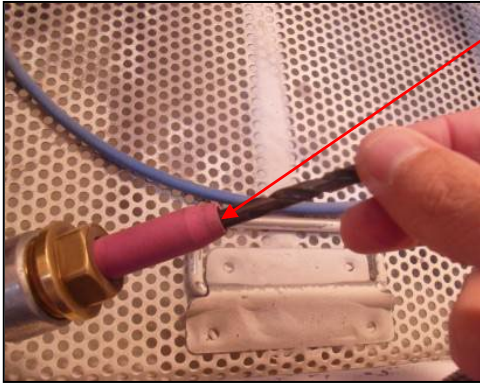

The picture below shows an extremely worn nozzle. Your nozzle should reach this state as it will decrease its blasting effectiveness and may also damage the blast gun.

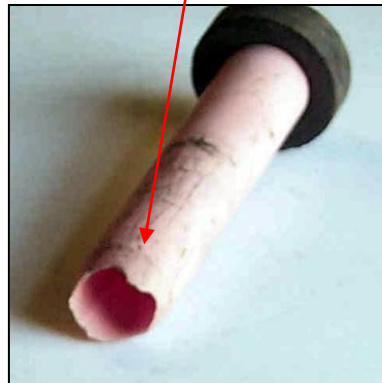

7.1.7.4 Airjet



The airjet should be withdrawn from the gun body after 8 hours blasting to establish the wear pattern on its outer surface. When wear has become noticeable, the fitting should be rotated to the next unworn section. When wear has occurred around the whole circumference, the airjet should be replaced.

7.1.7.5 Media entry

The media entry should be withdrawn from the gun body and inspected for wear on a regular basis.

7.1.8 Door seals

If the door gasket strips are worn then:

- this allows noise to escape the cabinet more easily
- media may be able to exit the cabinet

Item Code	Description
R5SL0024	16mm wide x 5m roll
R5SL0027	25mm wide x 5m roll



7.1.9 Topping up media

Top up the media levels as required as media is consumed. This can be roughly gauged from the waste bin on the dust collector. Regular additions of small quantities of media maintain an even particle size and assist in producing consistent results.

7.2 Weekly

- Inspect gauntlets for wear (see section [7.2.1](#))

7.2.1 Gauntlets

If the gauntlets (Y1AA0015, or Y1AA0014 for F1200), have holes in them or have split then:

- this allows noise to escape the cabinet more easily
- dust may be able to exit the cabinet



7.3 Monthly

- Drain old media and discard (see section [7.3.1](#)) and refill system with new media (see section [4.2](#))

7.3.1 Emptying media

To empty machine:

- Turn on the dust collector
- Use an airline or brush to clean inside cabinet
- Once clean leave dust extraction on for 10 minutes to clear pipes of residual media
- Switch off dust collector
- When motor has stopped remove pick-up tube from mixer box
- Place container under mixer box, unclip and remove mixer box and collect media



Refer to [5.1.2](#) on resetting the pickup tube after emptying the media.



TAKE CARE TO AVOID TRAPPING FINGERS; THE MIXER BOX COULD BE VERY HEAVY

8. FAQ's



FAULT-FINDING CHECKS SHOULD ONLY BE CARRIED OUT BY A FULLY QUALIFIED ENGINEER



IF REQUIRED THE AIR WASH CABINET SHOULD BE FULLY ISOLATED BEFORE PERFORMING ANY FAULT FINDING CHECKS



IF REQUIRED ENSURE ALL AIR SUPPLIES ARE TURNED OFF AND THE SYSTEM IS FULLY EXHAUSTED BEFORE PERFORMING ANY MAINTENANCE

Questions for Suction-feed machines

Fault	No air from blast gun when in cycle	Action
Possible cause	Bore of air-jet in blast gun blocked	Unblock and clean
	Nozzle blocked	Unblock and clean
Fault	Moisture coming from blast gun nozzle	Action
Possible cause	Fault with customer air supply	Customer to check and correct
Fault	Air pressure from blast nozzle drops	Action
Possible cause	Compressor fault/not to specification	Customer to check air supply and correct
	Incorrect mains supply pipe diameter	Refer to Data sheets, change pipe
	Worn air-jets or nozzle	Replace
	Faulty air valve	Replace
If problems are ongoing please conduct a full maintenance service of the equipment or contact Customer Services to book a Guyson Service Engineer visit		



9. Spares and servicing

A maintenance and service agreement for this system is available as an optional extra, for further details please refer to contact details below.

When ordering spares or accessories please quote the following information:-

Customer Account Number
Machine Serial Number
Product code of item required

If an item has broken that is not listed in the maintenance section and cannot be identified from the assembly drawings in the appendix of this manual then please contact Guyson International on the details below for further help.

Customer Service Department
Guyson International Ltd
Snaygill Industrial Estate
Keighley Road
Skipton
North Yorkshire
BD23 2QR

Tel: 01756-799911
E-mail: info@guyson.co.uk
Website: www.guyson.co.uk



9.1 Recommended spares list

DESCRIPTION - CABINET	1200	1400	1600	ITEM CODE
VIEWING WINDOW - 522 x 180 mm	x			P2GL0001
VIEWING WINDOW - 625 x 325 mm		x	x	P2GL0008
WINDOW GASKET	x	x	x	R5SL0028
ANTIFROSTING SHEET - 524 x 184 mm	x			P2PF0005
ANTIFROSTING SHEET - 625 X 325 mm		x	x	P2PF0008
FLOOR, FORMULA F1200	x			E1AA1675
FLOOR, FORMULA F1400		x		E1AA1655
FLOOR, FORMULA F1600			x	E1AA1563
AIR HOSE, 10 mm bore	x	x	x	R6TB0003
MEDIA HOSE - 10 mm bore	x			R6TB0014
MEDIA HOSE - 16 mm bore		x	x	R6TB0018
PICK-UP TUBE - 10 mm hose	x			E1AA3672
PICK-UP TUBE - 16 mm hose		x	x	E1AA4060
MIXER BOX	x	x	x	E1AA2452
BULKHEAD LIGHT FITTING BC	y	y	y	P3LG0029
BULKHEAD LIGHT FITTING ES	y	y	y	P3LG0030
FIXED GAUNTLET - 24"	x			Y1AA0014
FIXED GAUNTLET - 26"		x	x	Y1AA0015
ARMHOLE BEZEL - ROUND - F1200	x			Y1AB0007
ARMHOLE BEZEL - ROUND - F1400/1600		x	x	Y1AA0028
100 mm DIA HOSE SPINNING	x	x	x	Y2AB0013
EXHAUST HOSE 100 mm dia	x	x	x	R6TB0030
SIDE DOOR CATCH	x	x	x	P2HD0004
BREATHER PAD	x	x	x	Y1AB0001
BREATHER PAD BEZEL - ROUND	x	x	x	Y1AB0007
FOOT PEDAL VALVE	x	x	x	P4VL0555
DOOR SWITCH	x	x	x	P4VL0551
DOOR SEAL STRIP 16mm WIDE x 5M ROLL	x	x	x	R5SL0024
DOOR SEAL STRIP 25mm WIDE x 5M ROLL	x	x	x	R5SL0027

DESCRIPTION – DUST COLLECTOR	ITEM CODE
FILTER BAG, F21 or F41 D/C	Y1CA0000
IMPELLOR – WITH BOSS F21/F41 D/C	D2DA0005
MOTOR – 370W – SINGLE PHASE	P3MT0000
MOTOR – 370W – THREE PHASE	P3MT0001

DESCRIPTION – BLAST GUN	PRODUCT CODE
GUN BODY, ALUMINIUM 3/8" inlet	
NOZZLE, CERAMIC 6.4 mm bore	D2BA0001
NOZZLE, TUNGSTEN 6.4 mm bore	D2BA0004
NOZZLE, CERAMIC 8.0mm bore	D2BA0002
NOZLE , TUNGSTEN 8.0mm bore	D2BA0005
NOZZLE LOCKNUT	D2AA0007
NOZZLE WASHER	P1WS0038
NOZZLE GROMMET	P2GT0012
AIRJET 2.0 mm bore	D1AA0000
AIRJET 2.4 mm bore	D1AA0001
AIRJET 2.8 mm bore	D1AA0002
AIRJET GASKET	P1WS0037
AIRJET COIL SPRING	P2SG0000
TOP NUT	D2AA0008



HOSETAIL (AIR)		P4CG0001
HOSETAIL (MEDIA)	F1200 ONLY	P4CG0006
HOSETAIL (MEDIA)	F1400/F1600	P4CG0002
TRIGGER VALVE	F1200 ONLY	P4VL0072

Please note the below parts are now obsolete, but may still be available as required for legacy machines.

DESCRIPTION – OBSOLETE LEGACY PARTS				PRODUCT CODE
COMBINED FILTER/REGULATOR	x	x	x	P4AP0050
FOOT PEDAL VALVE		x	x	P4VL0059
PNEUMATIC ISOLATOR 1/4" BSP	x	x	x	P4VL0115

10. Appendices

10.1 Electrical installation of dust collectors and cyclones

Guyson dust collectors and motorised cyclones (whether for single or three phase supplies), when supplied to complement blast cabinets, are fitted with starters. These should be wired from the customer's switched fused isolator. The starter needs to be wired up by a suitably qualified electrician; electrical schematics for the single and three phase systems are attached.

The supply required can be discovered from reading this chart:

Model	Phase	Voltage	Cycle (Hz)	Power (kW)	Full load current (A)*
21/41	1	230	50	0.37	3
41	3	400	50	0.37	1.4

* Fuses should be sized to comply with full load current. When sizing fuses, smallest fuse rating should be used to suit motor and starting characteristics.

SINGLE PHASE

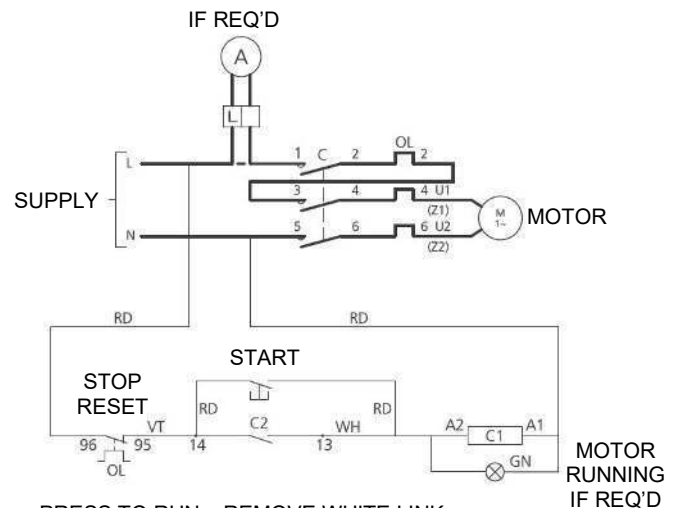
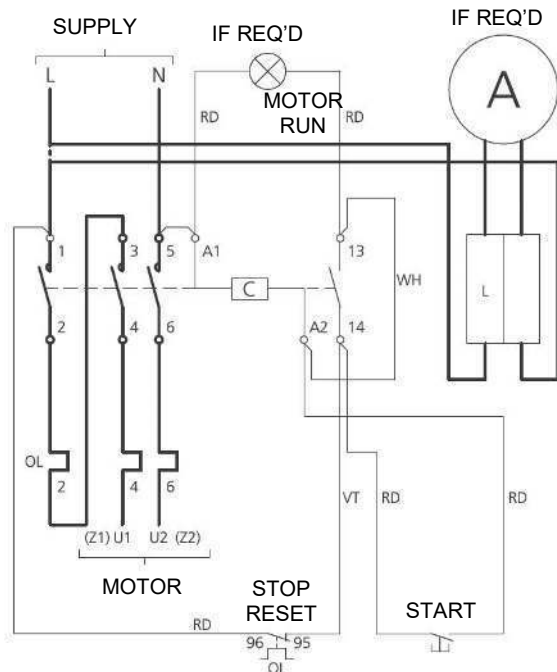

PRESS TO RUN – REMOVE WHITE LINK
SEPARATE NO-VOLT SUPPLY – REMOVE LINK BETWEEN 1 ON C & 96 ON OL AND 5 ON C & A1.
CONNECT SEPARATE SUPPLY TO 96 ON OL & A1

REMOTE INCH BUTTON
REMOVE WHITE LINK

REMOTE START-STOP BUTTONS
REMOVE VIOLET LINK

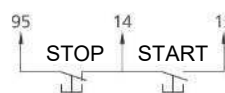

REMOTE CONTROL SWITCH
REMOVE VIOLET LINK

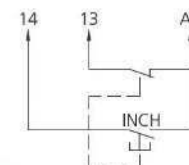
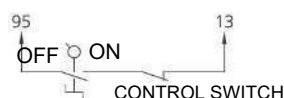

3 PHASE

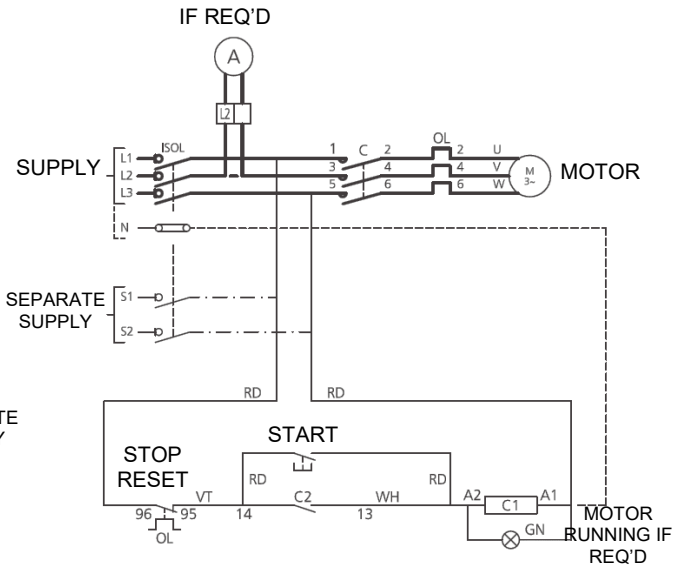
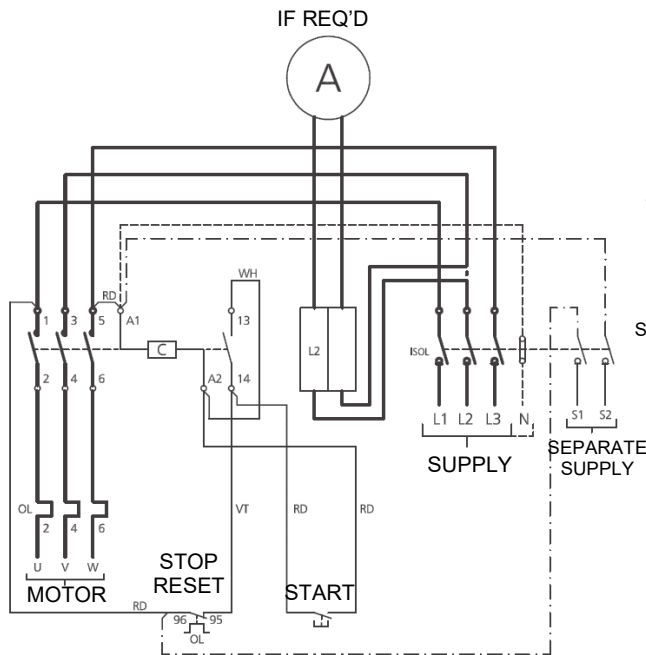

REMOTE START-STOP
BUTTONS
REMOVE VIOLET LINK

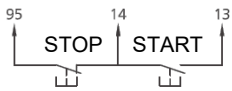

REMOTE CONTROL
SWITCH
REMOVE VIOLET LINK

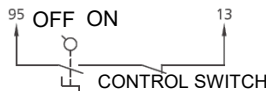

REMOTE INCH BUTTON
REMOVE WHITE LINK

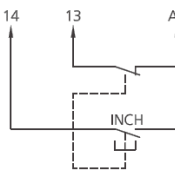

FOR LINE & NEUTRAL CONTROL, REMOVE
LINK BETWEEN A1 & 5 ON C AND WIRE AS
SHOWN DOTTED
PRESS TO RUN – REMOVE WHITE LINK
SEPARATE NO-VOLT SUPPLY – CONNECT AS
SHOWN

On both single and three phase motors it is essential to check that the direction of rotation matches the arrow attached to the motor housing. This is best done visually. If the motor is rotating in the wrong direction, it will be necessary to switch off the machine, isolate the electric supply and reverse the position of L1 and L2 on single phase machines or any TWO of the feed wires (L1, L2 or L3) on three phase machines.



If a problem occurs with installation then Guyson International should be contacted to provide support

When fitting a new motor starter, the overload will have to be set to the required full load current. Use the table at the start of this section to select the correct value, and adjust the overload accordingly.



To adjust, pull out selector
and slide to required position